

**Features**

- Remote microphone with eight (8) soft keys
- Equipped with microphone
- Remote microphone prioritization using Potter Fire Programmer
- P-Link Device - 30 remote microphones per panel
- Status and Trouble LED indicators
- ThumbLock option
- The product includes a 5-year warranty
- Network Paging and Network ECS coming soon



**Description**

The RM-1000ECS remote microphone allows the operator to page and activate ECS messages to desired speaker circuits from a remote area. The remote microphone is equipped with an SB-8 voice user interface which provides 8 programmable soft keys. It is enclosed in a sheet metal enclosure and is equipped with a microphone. The RM-1000ECS is a PLink device and communicates with the control panel via the 4-wire RS-485 connection and distributes paging audio through the V-Link 1 and V-Link 2 audio riser. A maximum of 30 RM-1000ECS can be connected to a voice system. The remote microphone provides LED indication for Power and Ready to Page.

**Installation**

The RM-1000ECS is connected to the fire alarm control panel using the P-Link and V-Link. The connection is power limited and supervised. Up to 30 RM-1000ECS remote microphones can be connected to an integrated voice system.

Figure 1. RM-1000ECS Enclosure

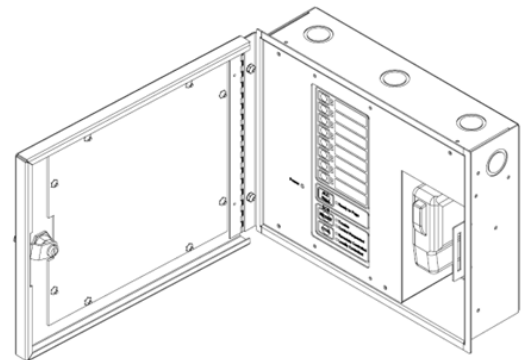

**Technical Specifications**

Standby Current	34 mA
Alarm Current	55 mA
Operating Temperature Range	32° to 120° F (0° to 49°C)
Operating Humidity Range	10% to 93% (non-condensing)

**Ordering Information**

Model	Description	Stock No
RM-1000ECS	Remote Microphone w/ 8 Switches	3520679