



IFS-WP1 Stock No. 9000005
IFS-WP2 Stock No. 9000006
IFSS-WP1 Stock No. 9000314
IFSS-WP2 Stock No. 9000315

General

The Model IFS-WP is a flow switch used in liquid flow lines carrying water or any fluid not harmful to brass, stainless steel, or EPDM and not classified as a hazardous fluid.

This switch can serve as a way to start and stop electrically operated equipment when a flow or no flow condition occurs in a variety of applications.

This device is designed for use only as an operating control. Where an operating control failure would result in personal injury and/or loss of property, it is the responsibility of the installer to add devices (safety, limit controls) that protect against, or systems (alarm, supervisory systems) that warn of control failure.

Listings/Approvals:

- UL Guide (NKPZ) for industrial control equipment per UL Standard 508 Industrial Control Equipment
- UL Guide (MFHX) for heating/cooling appliance switch per UL Standard 353 Limit Controls
- CSA Class (321106) for industrial control equipment per CSA Standard C22.2 No. 14-M Industrial Control Equipment
- CE Marked

Maximum Service Pressure: 250 PSI

Enclosure: Die-cast grey powdercoat finish on cover.
Plated steel base.
Not for use in hazardous locations.

Contacts:

IFS-WP1 / IFSS-WP1: One SPDT (Form C) switch
IFS-WP2 / IFSS-WP2: Two sets of SPDT (Form C) switches to provide versatility in wiring two separate circuits.
15 Amps at 125/250VAC
.5 Amps at 125VDC
.25 Amps at 250VDC

Motor Ratings : 120VAC 240VAC

Horsepower : 1/8 1/4
AC F.L.A. : 3.8 2.9
AC L.R.A. : 22.8 17.4

Pilot Duty Rating : 125VA 120/240VAC

Environmental Specifications:

- Suitable for indoor or outdoor use with factory installed gasket and die-cast housing.
- NEMA 4 Rated Enclosure - use with appropriate conduit fitting.

Ambient Temperature Range:

32°F to 176°F (0°C to 80°C)

Media Temperature Range:

32°F to 250°F (0°C to 121°C)

IFS-WP1 / IFS-WP2 Pipe Connection:

1 in. NPT Brass

IFSS-WP1 / IFSS-WP2 Pipe Connection:

1 in. NPT 316 Stainless Steel

Conduit Entrance: One opening for 1/2" conduit

Usage: For pipe sizes 1" - 8"

Caution: This device is not intended for applications in explosive environments.

Mounting And Installation

The Model IFS-WP may be mounted in a horizontal pipe line or a vertical pipe line with upward liquid flow. It is not recommended for installations where flow is downward. When mounted in a horizontal pipe line the switch will trip at a lower flow rate than shown in Fig. 6.

Mount the device in a section of pipe where there is a straight run of at least 5 pipe diameters on each side of the flow switch. Do not locate adjacent to valves, elbows or orifices. The switch should be mounted so the terminals or wire leads are easily accessible for wiring.

IFS models with flexible paddles are furnished with 4 paddles. Rigid paddle models are furnished with 2 paddles. For pipe sizes 1", 2", 3", 6", or 8", use the paddles provided. Intermediate sizes may be trimmed from the appropriate paddle using the paddle template in Fig. 3. The paddle must not touch the inside of the pipe or bind in any way. Paddles smaller than the actual pipe size should be used for added support and higher sensitivity. See Fig. 2. The paddles must be properly attached and the screw that holds the paddle must be securely tightened.

For a 1" pipe application mount in a standard 1" x 1" x 1" tee. Use a reducing tee for larger sizes of pipe to keep flow switch close to pipe and provide adequate paddle length in the flow stream.

Example: Use a 2" x 2" x 1" tee for 2" pipe. A weldolet may also be used. Screw the device into the tee fitting as shown in Fig. 4. The flat of the paddle must be at a right angle to the flow. The arrow on the side of the bushing must point in the direction of flow.

Fig. 1

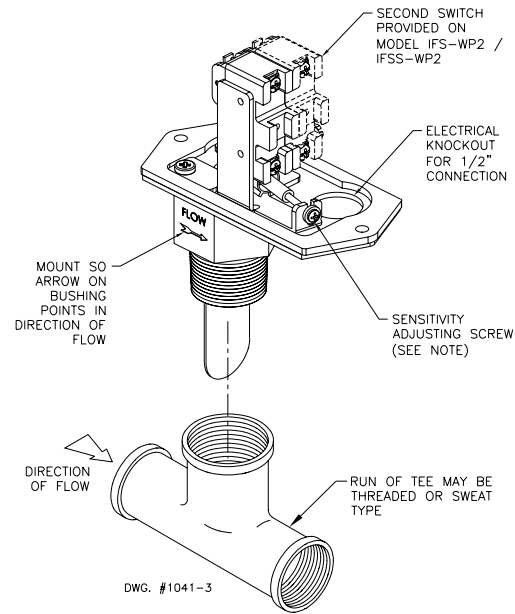

NOTE: Turn screw clockwise to increase the flow rate required to activate the switch.
Turn screw counter-clockwise to decrease the flow rate required to activate the switch.

Fig. 2

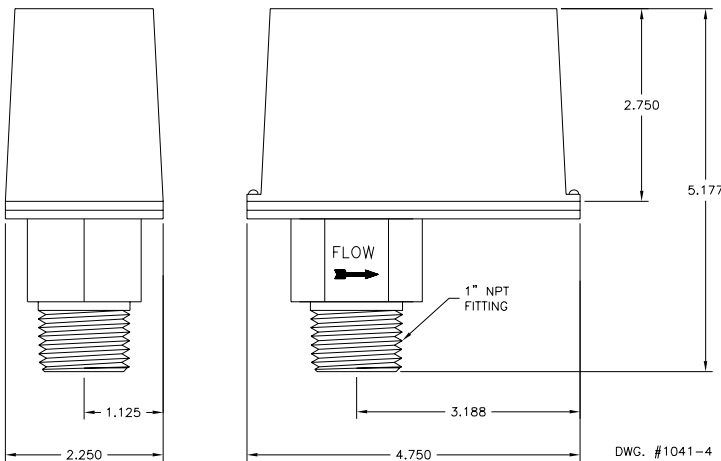

Fig. 3
Typical paddle arrangement for 6" to 8" pipe.

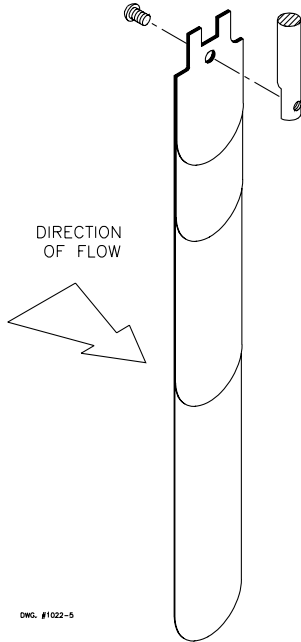
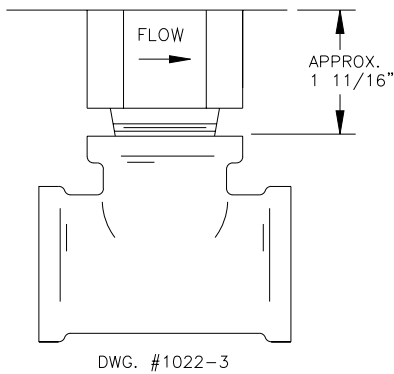

Fig. 4



CAUTION

Screw the device into the TEE fitting as shown. Care must be taken to properly orient the device for the direction of the flow. Do not tighten by grasping the switch enclosure. Use the wrenching flats on the bushing only. Turning radius required for mounting the IFS-WP is 3.188".

Fig. 5
Use the drawing as a template and trim at the dotted arc when trimming the appropriate paddle for intermediate pipe sizes.

CAUTION

The paddle must not touch the inside of the pipe or bind in any way.

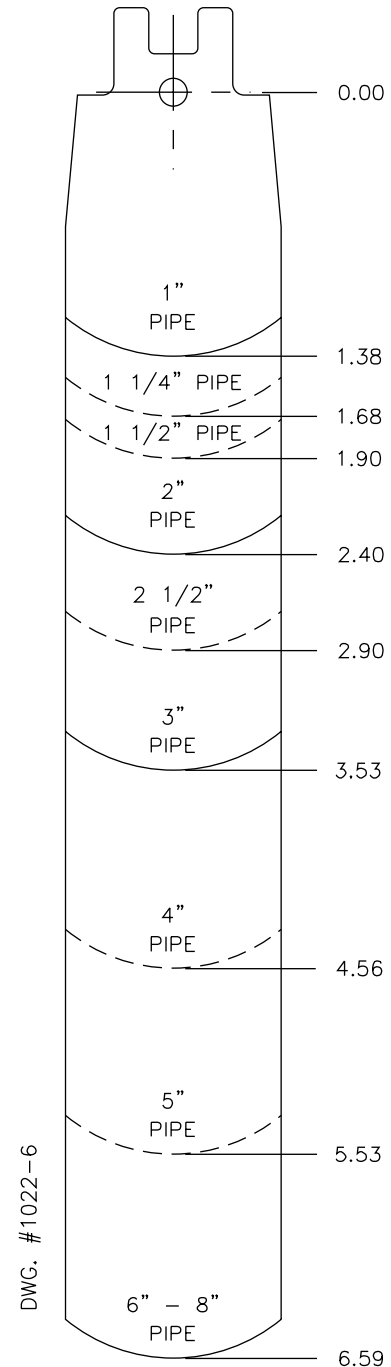

Wiring

Use properly rated temperature supply wire for the anticipated service temperature.

Make all electrical connections in accordance with the National Electrical Code and local regulations.

See Fig. 6 for diagram illustrating switch action.

Adjustment

Remove switch cover and turn the sensitivity adjusting screw clockwise to increase the flow rate required to actuate the switch. Turn the sensitivity

adjusting screw counter-clockwise to decrease the flow rate required to actuate the switch. (See Fig. 1.) Be sure to replace the cover upon completion of the installation and adjustment.

⚠ CAUTION

Check the installation for "no-flow" switch operation. Make appropriate adjustments to the sensitivity adjustment screw to be sure the switch restores fully at the desired flow rate.

Fig. 6 Switch Information

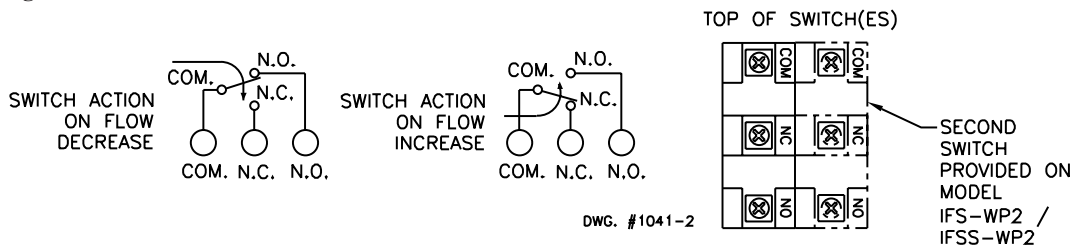

Fig. 7

SPECIFICATIONS											
Typical Flow Rates-GPM Required to Actuate Switch (For vertical pipe installations)											
Pipe Size (inches)		1	1 1/4	1 1/2	2	2 1/2	3	4	*5	6	*8
Minimum Adjustment	Flow Increase	4.5	4.5	6.0	7.5	13.5	18	35	50	70	210
	Flow Decrease	3.5	3.5	5.0	5.5	9.5	13	25	40	60	190
Maximum Adjustment	Flow Increase	9.5	10.0	13.5	20.0	29.0	50	70	120	180	410
	Flow Decrease	7.0	8.5	10.5	18.5	26.0	45	65	105	160	380

NOTES:

1. Typical flow rates for 1" to 1 1/2" pipe sizes are averages which may vary approximately ± 1 GPM with the use of a bronze reducing tee.
 2. Typical flow rates for 2" to 8" pipe sizes are averages which may vary $\pm 10\%$ with the use of a 1" weldolet.
- (*). Flow rates for these sizes are calculated.