

Features

- One (1) Class B monitoring input
- SLC Class A, Class X & Class B
- Mounts in a standard 4" or double gang box
- Wiring terminals accessible when mounted in box
- All wiring terminals accept 22 to 12 AWG
- Product includes a 5 year warranty

NOTE: This addressable module does not support 2-wire smoke detectors.



Description

The PAD100-SIM uses one (1) SLC loop addresses when monitoring one (1) Class B circuit. The module mounts on either a 4" square or double gang box. The module is capable of monitoring one (1) Class B circuit. The PAD100-SIM includes one red LED to indicate the module's status. In normal condition, the LED flashes when the device is being polled by the control panel. When the input is activated, the LED will flash at a fast rate.

Application

The PAD100-SIM is compatible with Potter's IPA series addressable fire alarm control panels. The PAD100-SIM is an interface module used to monitor dry contact devices such as sprinkler waterflow, valve tamper switches, or conventional pull stations. The module is capable of monitoring one Class B circuit.

Setting the Address

Each addressable SLC device must be assigned an address. The address is set using the DIP switch located on the PAD100-SIM.

Before connecting a device to the SLC loop, take the following precautions to prevent potential damage to the panel or device:

1. Power to the device is removed.
2. Field wiring is correctly installed.
3. Field wiring has no open or short circuits.

Technical Specifications

| | |
|-------------------------------|---|
| Operating Voltage | 24.0V |
| Max SLC Standby Current | 240 μ A |
| Max SLC Alarm Current | 240 μ A |
| Max Wiring Resistance of IDC | 100 Ω |
| Max Wiring Capacitance of IDC | 1 μ F |
| EOL Resistor | 5.1K Ω |
| Operating Temperature Range | 32 to 120°F (0 to 49°C) |
| Operating Humidity Range | 0 to 93% (non-condensing) |
| Max no. of Module Per Loop | 127 units |
| Dimensions | 4.17" (106mm)L \times 4.17" (106mm)W \times 1.14" (29mm)D |
| Mounting Options | Standard 4" Square or Double Gang Box |
| Shipping Weight | 0.6 lbs |

Installation Using Compatible Electrical Box

Fig 1

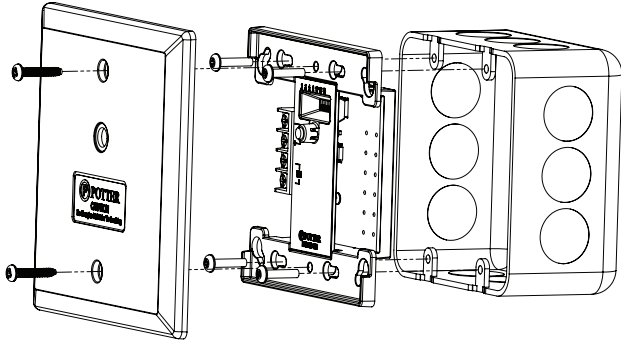

Wiring Diagram

PAD100-SIM With Class B Circuit

Fig 2

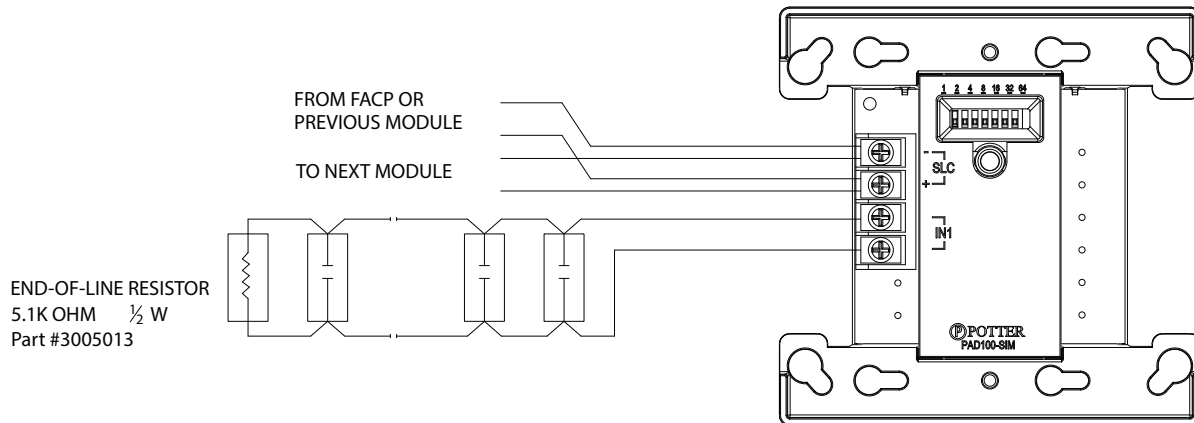

Ordering Information

| Model | Description | Stock No. |
|------------|---------------------|-----------|
| PAD100-SIM | Single Input Module | 3992704 |