

Features

- Two switch model.
- Independent switch adjustment, no tools needed.
- Two conduit / cable entrances.
- Separate isolated wiring chambers.
- Non-corrosive pressure connection.
- Solid metal enclosure.



NOTICE

This document contains important information on the installation and operation of PS25 pressure switches. Please read all instructions carefully before beginning installation. A copy of this document is required by NFPA 72 to be maintained on site.

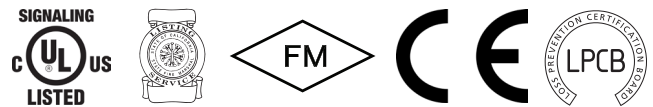

Installation

The Potter PS25 Series Supervisory Pressure Actuated Switches are designed primarily to detect an increase and/or decrease from normal system pressure in automatic fire sprinkler systems. Typical applications are: air/nitrogen supervision in dry pipe and pre-action systems, pressure tanks, air supplies, and water supplies. The PS25-2 has two switches. The Low switch is factory set to activate at approximately 18 psi (1,2 BAR) on a decrease in pressure. The High switch is factory set to activate at approximately 28 psi (1,9 BAR) on an increase in pressure. NFPA 72 requires a supervisory signal for both high and low pressure conditions. The PS25 is factory set for a normal air pressure of 23 psi. See section heading Adjustments and Testing if other than factory set point is required.

1. Connect the PS25 to the system side of any shutoff or check valve.
2. Apply Teflon tape to the threaded male connection on the device. (Do not use pipe dope)
3. Device should be mounted in the upright position. (Threaded connection down)
4. Tighten the device using a wrench on the flats on the device.

Technical Specifications

Dimensions	3.78"(9,6cm)Wx3.20"(8,1cm)Dx4.22"(10,7cm)H
Differential	Typical 1 lb. at 10 PSI (.07 at ,7 BAR) 4 lbs at 60 PSI (.28 at 4,1 BAR)
Enclosure	Cover: Die Cast Finish: Red Powder Coat Base: Die Cast All parts have corrosion resistant finishes
Cover Tamper	Cover incorporates tamper resistant fastener that requires a special key for removal. One key is supplied with each device.
Factory Adjustment	PS25-2 operates on increase at 28 PSI (1,9 BAR) and on decrease at 18 PSI (1,2 BAR)
Contact Ratings	(2) SPDT (Form C) Switches 10.1 Amps at 125/250 VAC, 2.0 Amps at 30 VDC
Environmental Limitations	-40° F to 140°F (-40°C to 60°C) NEMA 4/IP66 Rated Enclosure indoor or outdoor when used with NEMA 4 conduit fittings
Conduit Entrances	Two knockouts for 1/2" conduit provided. Individual switch compartments and ground screw suitable for dissimilar voltages
Service Use	NFPA 13, 13D, 13R, 72
Pressure Connection	Nylon 1/2" NPT male
Pressure Range	10-60 PSI (.7-4,1 BAR)
Maximum System Pressure	300 PSI (20,68 BAR)

Wiring Instructions

1. Remove the tamper resistant screw with the special key provided.
2. If it is necessary to remove the sealed knockouts, carefully place a screwdriver on the edge of the knockout and sharply apply a force sufficient to dislodge the knockout plug. See Fig. 9.
3. Run wires through an approved conduit connector and affix the connector to the device. A NEMA-4 rated conduit fitting is required for outdoor use.
4. Connect the wires to the appropriate terminal connections for the service intended. See Figures 2,4,5,6 and 8.

Adjustment and Testing

NOTE: Testing the PS25 may activate other system connected devices. The operation of the pressure supervisory switch should be tested upon completion of installation and periodically thereafter in accordance with the applicable local, national and NFPA codes and standards and/or the authority having jurisdiction (manufacturer recommends quarterly or more frequently).

The use of a Potter BVL (see product bulletin 5400799 for details) is recommended to facilitate setting and testing of the PS25 pressure switch. When a BVL (bleeder valve) is used, the pressure to the switch can be isolated and bled from the exhaust port on the BVL without affecting the supervisory pressure of the entire system. See Fig. 3.

The operation point of the PS25 Pressure Switch can be adjusted to any point between 10 and 60 PSI (0,7 - 4,11 BAR) by turning the adjustment knob(s) clockwise to raise the actuation point and counter clockwise to lower the actuation point. In the case of the PS25-2, both switches operate independent of each other. Each switch may be independently adjusted to actuate at any point across the switch adjustment range. If the pressure needs to be adjusted from the factory settings, adjust the system pressure to the desired trip point. Use an ohmmeter on the appropriate contact (COM and 2 for pressure decrease and COM and 1 for pressure increase). Adjust the knurled knob until the meter changes state. At that point the switch is set for that particular pressure. Final adjustments should be verified with a pressure gauge.

The position of the top of the adjustment knob across to the printed scale on the switch bracket can be used to provide an approximate visual reference of the pressure switch setting.

Dimensions

Fig 1

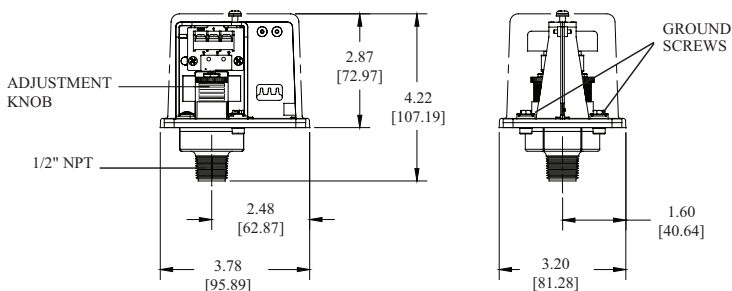

NOTE: To prevent leakage, apply Teflon tape sealant to male threads only.

DWG# 930-1

Switch Terminal Connections Clamping Plate Terminal

Fig 2

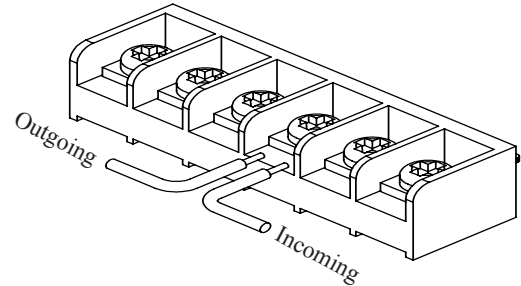

WARNING

An uninsulated section of a single conductor should not be looped around the terminal and serve as two separate connections. The wire must be severed, thereby providing supervision of the connection in the event that the wire becomes dislodged from under the terminal.

Typical Sprinkler Applications

Fig 3

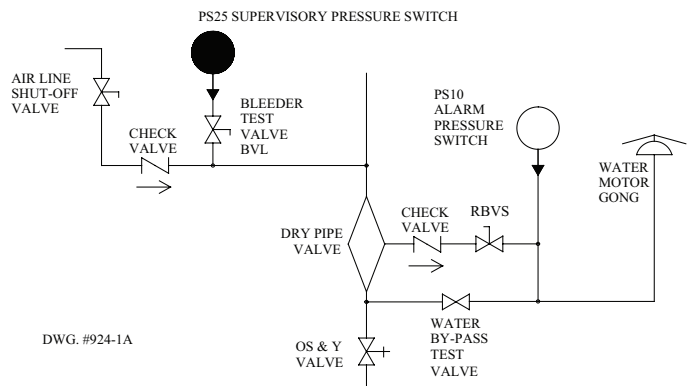

CAUTION

Closing of any shutoff valves between the alarm check valve and the PS25 will render the PS25 inoperative. To comply with IBC, IFC, and NFPA-13, any such valve shall be electrically supervised with a supervisory switch such as Potter Model RBVS.

Typical Electrical Connections

Fig 4

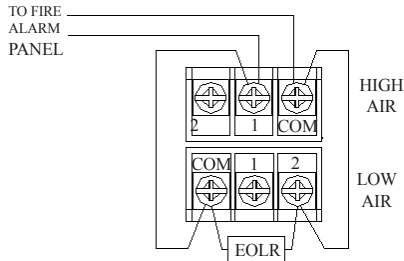

WITH NORMAL SYSTEM PRESSURE APPLIED HIGH - TERMINAL 1 WILL CLOSE ON PRESSURE INCREASE.

WITH NORMAL SYSTEM PRESSURE APPLIED LOW - TERMINAL 2 CLOSURES ON PRESSURE DROP.

Low Pressure Signal Connection

Fig 5

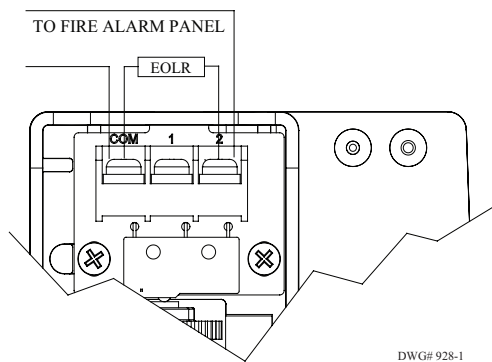

High Pressure Signal Connection

Fig 6

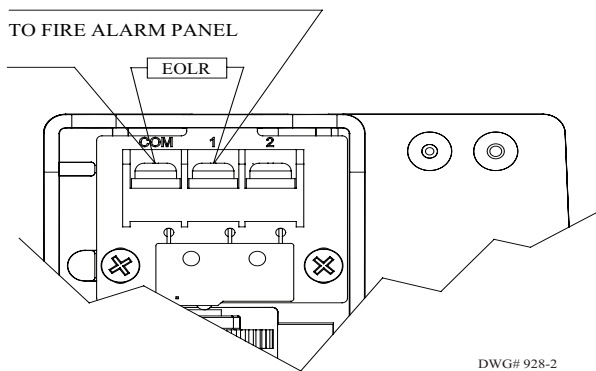

One Conduit Wiring

Fig 7

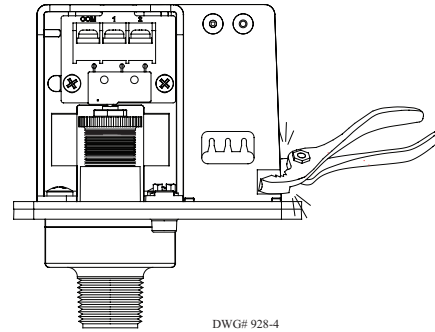

DWG# 928-4

Changing Pressure

Fig 8

Low Pressure Switch

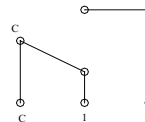

High Pressure Switch

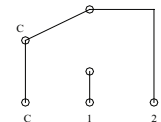

Terminal

C: Common

1. Closed when installed under normal system pressure.
2. Open when installed under normal system pressure. Closes on pressure drop. Use for low air signal.

Terminal

1. Open when installed under normal system pressure. Closes on increase in pressure. Use for high air signal.
2. Closed under normal system pressure.

Removing Knockouts

Fig 9

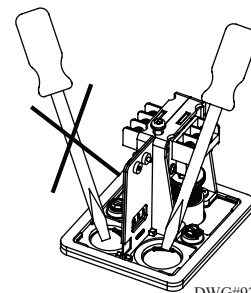

DWG#928-5

Engineer/Architect Specifications Pressure Type Waterflow Switch

Pressure type supervisory switches; shall be a Model PS25 as manufactured by Potter Electric Signal Company, St. Louis, MO., and shall be installed on the fire sprinkler system as shown and or specified herein.

Switches shall be provided with a 1/2" NPT male pressure connection to be connected into the air supply line on the system side of any shut-off valve. A Model BVL bleeder valve as supplied by Potter Electric Signal Company of St. Louis, MO., or equivalent shall be connected in line with the PS25 to provide a means of testing the operation of the supervisory switch. (See Fig. 3)

The switch unit shall contain SPDT (Form C) switch(es). One switch shall be set to operate at 18 psi (1,2 BAR) on a pressure decrease. The second switch shall be set to operate at a 28 psi (2,9 BAR) on a pressure increase.

Switch contacts shall be rated at 10.1 Amps at 125/250VAC and 2.0 Amps at 30VDC. The units shall have a maximum pressure rating of 300 PSI (20,68 BAR) and shall be adjustable from 10 to 60 PSI (0,7 to 4,1 BAR).

Pressure switches shall have two conduit entrances, one for each individual switch compartment to facilitate the use of dissimilar voltages for each individual switch.

The cover of the pressure switch shall be zinc die-cast with rain lip and shall attach with one tamper resistant screw. The pressure switch shall be suitable for indoor or outdoor service with a NEMA-4/IP66 rating.

The pressure switch shall be UL, ULC, and CSFM listed, FM and LPC approved and NYMEA accepted.

Ordering Information

Model	Description	Stock No.
PS25-2	Pressure Switch with two sets SPDT contacts	1340425
	Hex Key	5250062
BVL	Bleeder Valve	1000018
	Optional Cover Tamper Switch Kit	0090200

WARNING

- Installation must be performed by qualified personnel and in accordance with all national and local codes and ordinances.
- Shock hazard. Disconnect power source before servicing. Serious injury or death could result.
- Read all instructions carefully and understand them before starting installation. Save instructions for future use. Failure to read and understand instructions could result in improper operation of device resulting in serious injury or death.
- Risk of explosion. Not for use in hazardous locations. Serious injury or death could result.

CAUTION

- Do not tighten by grasping the switch enclosure. Use wrenching flats on the bushing only. Failure to install properly could damage the switch and cause improper operation resulting in damage to equipment and property.
- To seal threads, apply Teflon tape to male threads only. Using joint compounds or cement can obstruct the pressure port inlet and result in improper device operation and damage to equipment.
- Do not over tighten the device, standard piping practices apply.
- Do not apply any lubricant to any component of the pressure switch.